

Fitting instructions

Make: Toyota

Corolla Verso; 02-2004->

Type: 4437

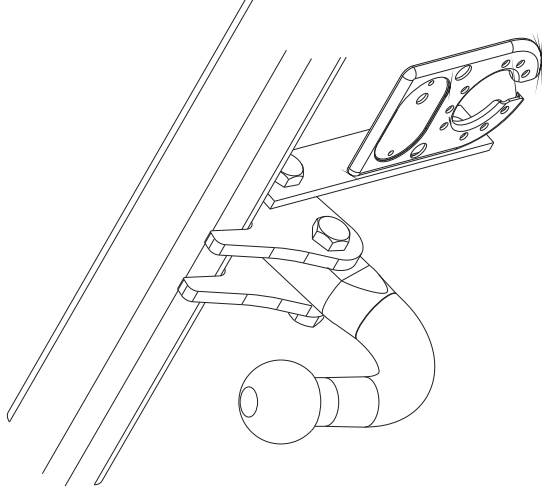

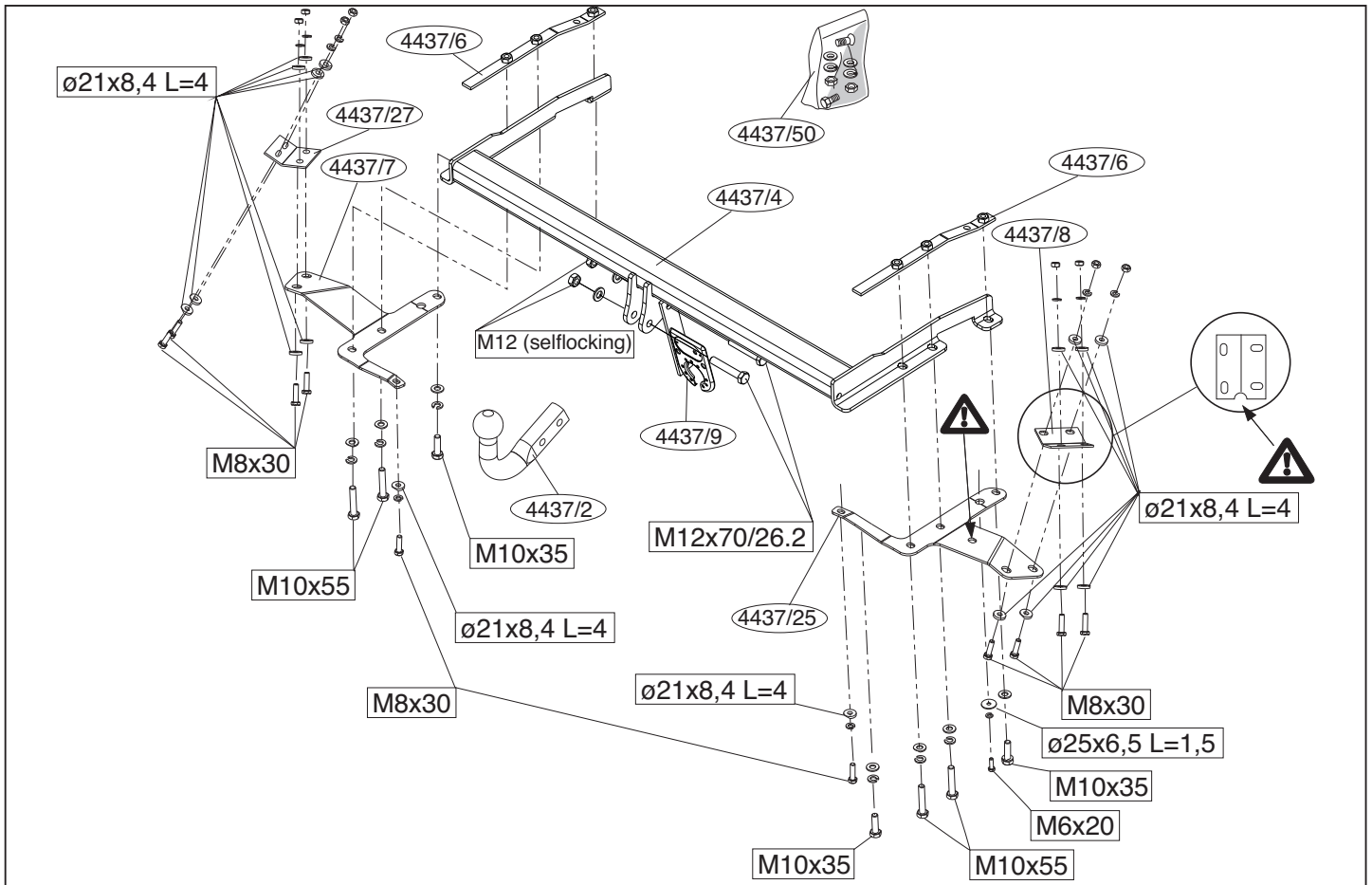

© 443770/27-08-2004/1



Dispositivo di traino tipo: 4437  
 Per autoveicoli: Toyota Corolla Verso 02-2004->  
 Tipo funzionale:

Classe e tipo di attacco: A50-X  
 Omologazione: e11 00-5119  
 Valore D: 8,6 kN  
 Carico Verticale max. S: 60 kg  
 Larghezza rimorchiabile per Caravan e T.A.T.S.: 2,45m vedere CARTA di CIRCOLAZIONE VEICOLO (motrice) + 70 cm = ..arrotondare ai 5 cm superiore (vedi D.M.28/05/85)  
 Massa rimorchiabile: vedi carta di circolazione dell' autoveicolo

**Per verificare l'idoneità del dispositivo di traino omologato a norma CEE 94/20, all'installazione sulla vettura su cui si intende procedere al montaggio, compilare la seguente formula (se necessario declassare la massa rimorchiabile):**

$$D = \frac{T \times C}{T + C} \times 0,00981 = \dots\dots \text{kN}$$

dove: T= Massa Complessiva Max. della motrice (in kg)  
 C= Massa Rimorchiabile Max. della motrice (in kg)

**DA COMPILARE PER IL COLLAUDO**

**DICHIARAZIONE DI CORRETTO MONTAGGIO:** la sottoscritta Ditta dichiara di aver montato in maniera corretta ed in conformità alle prescrizioni sia del costruttore del veicolo che del costruttore del dispositivo stesso il seguente dispositivo di attacco meccanico:

tipo:.....  
 Il dispositivo di attacco sopra indicato è stato installato su autoveicolo  
 modello:.....  
 targa:.....  
 Data:.....

**TIMBRO e FIRMA**

Si dichiara inoltre di aver informato l'utente del veicolo sull'USO e MANUTENZIONE del dispositivo stesso.

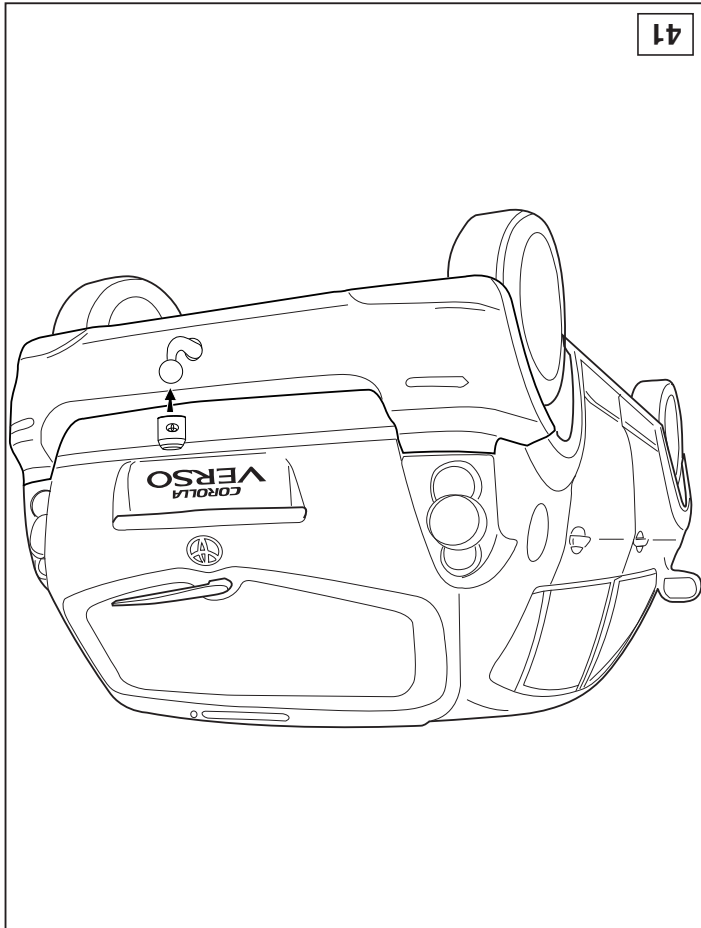
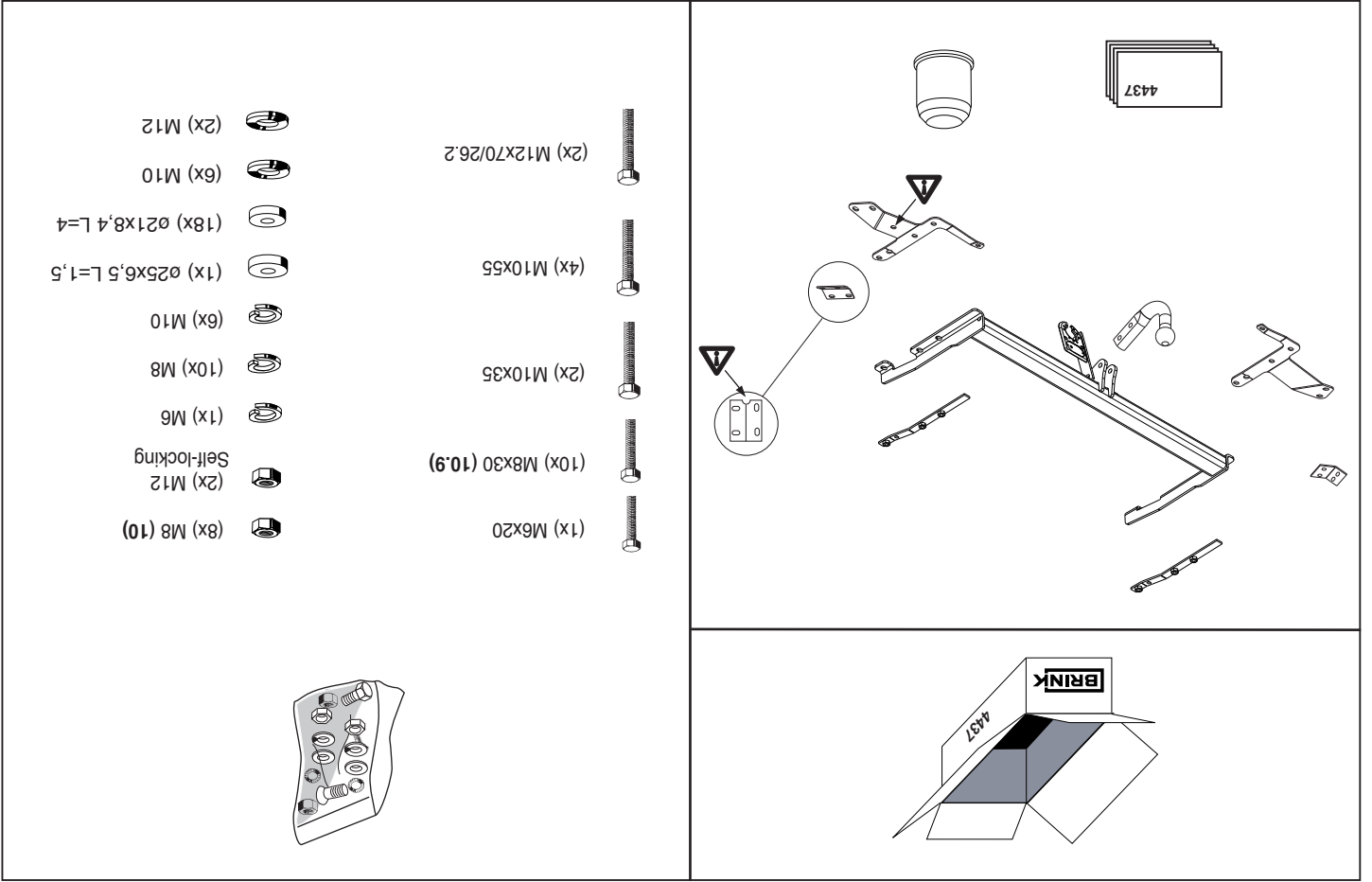

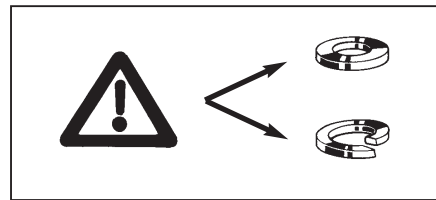
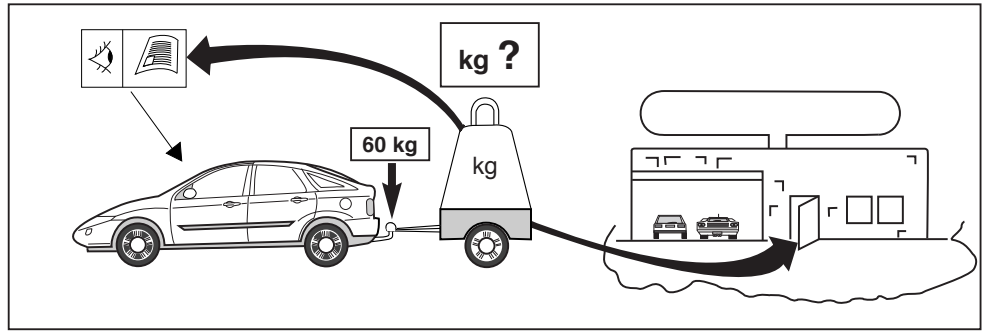
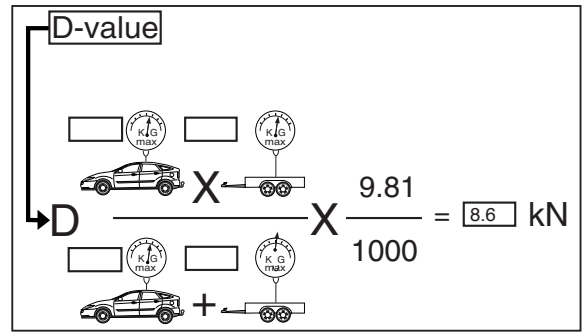
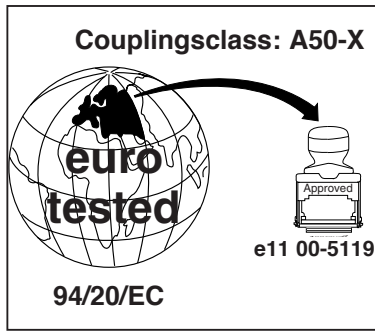
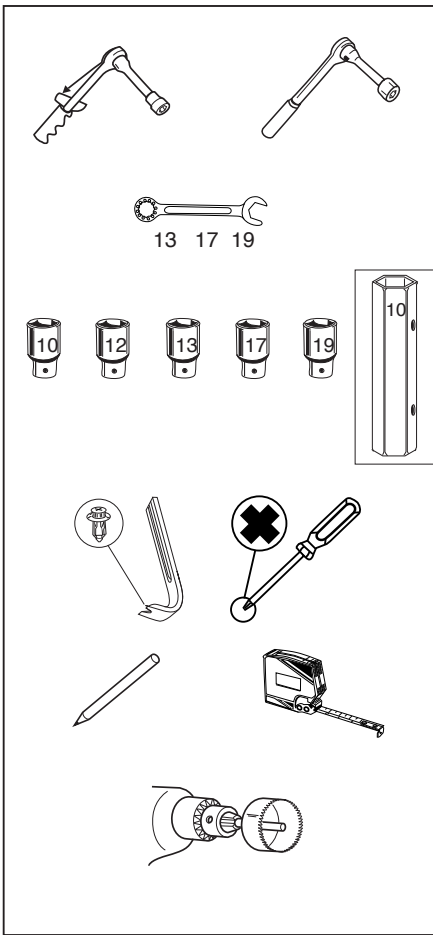

© 443770/27-08-2004/3

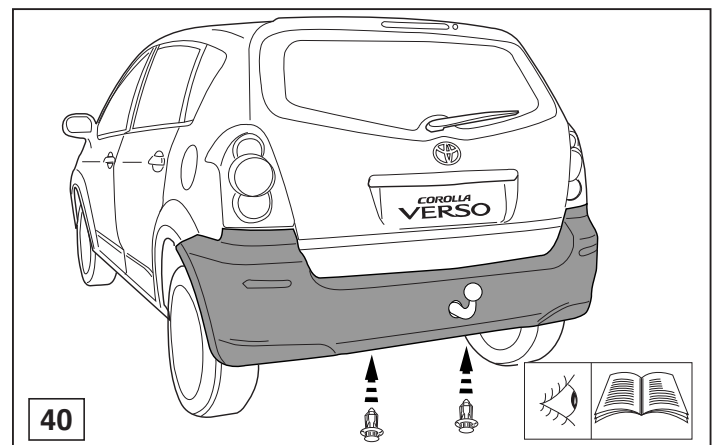
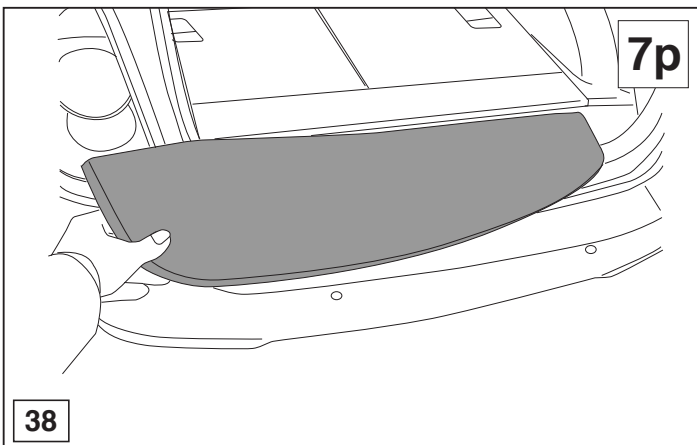
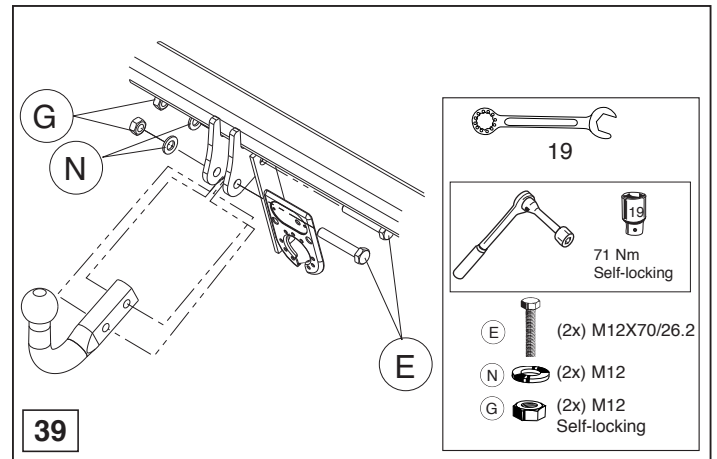
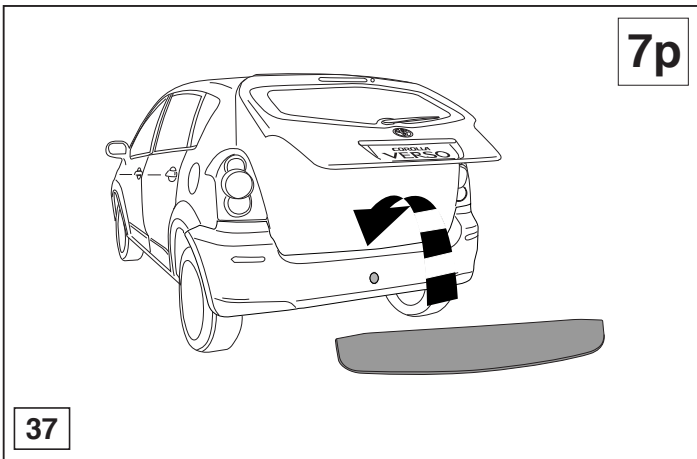

© 443770/27-08-2004/16



1000km

+



0km

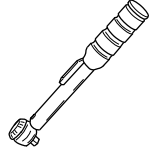

  



M6  
9,5 Nm



M8  
35 Nm



M10  
46 Nm



M12  
79 Nm

**Torque settings for nuts and bolts (8.8)**

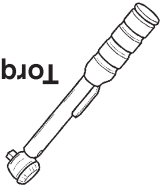

**HINWEISE:**

\* Die für das Fahrzeug zugelassene Anhängelast ist den Fahrzeug Unterlagen zu entnehmen. Bei Änderungen des Fahrzeuggewichtes muß die höchstzulässige Anhängelast gegebenenfalls aus dem D-Wert nachgerechnet werden.

\* Auskunft hierüber kann ihr Fachhändler oder der TÜV geben.

\* Elektrische Anlage gemäß STVZO anbringen.

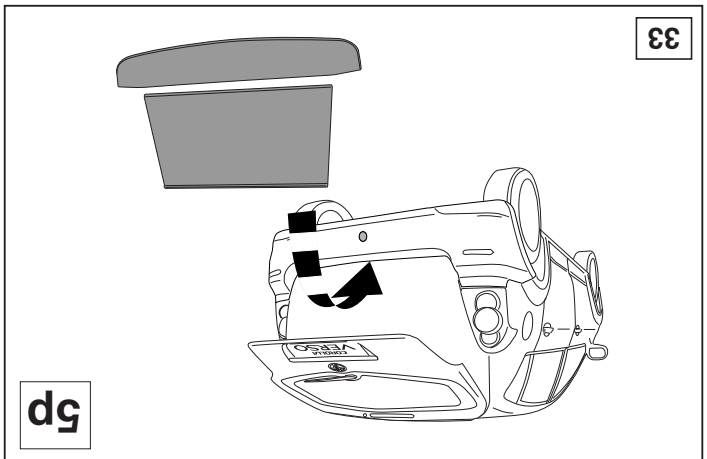
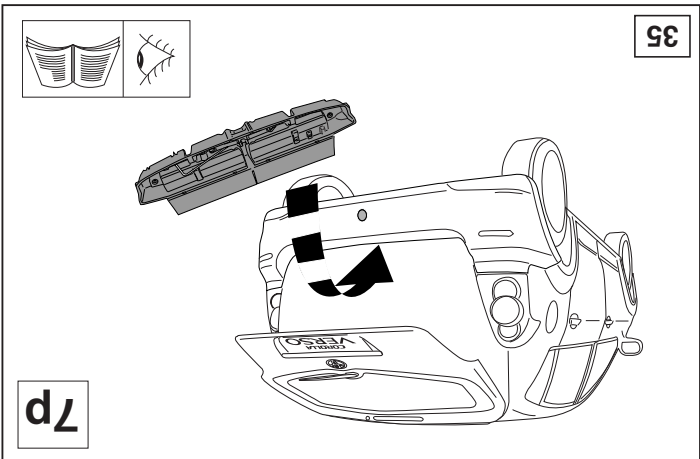
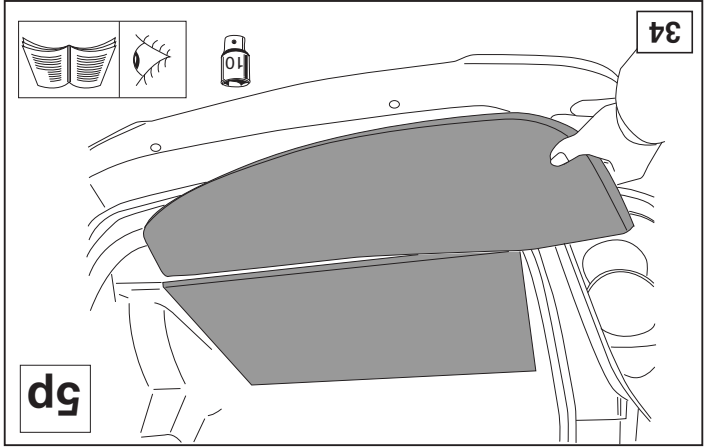
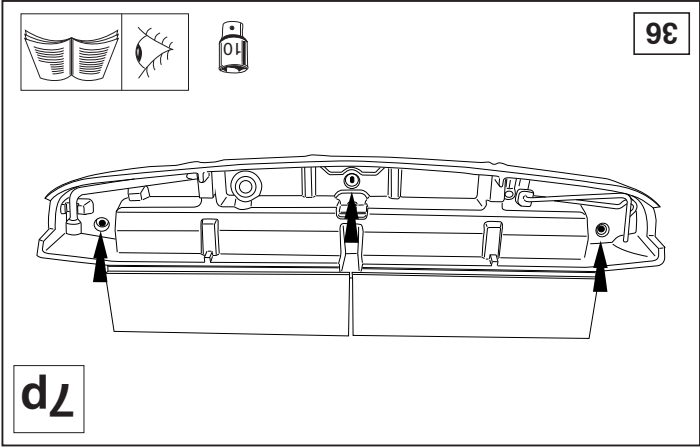

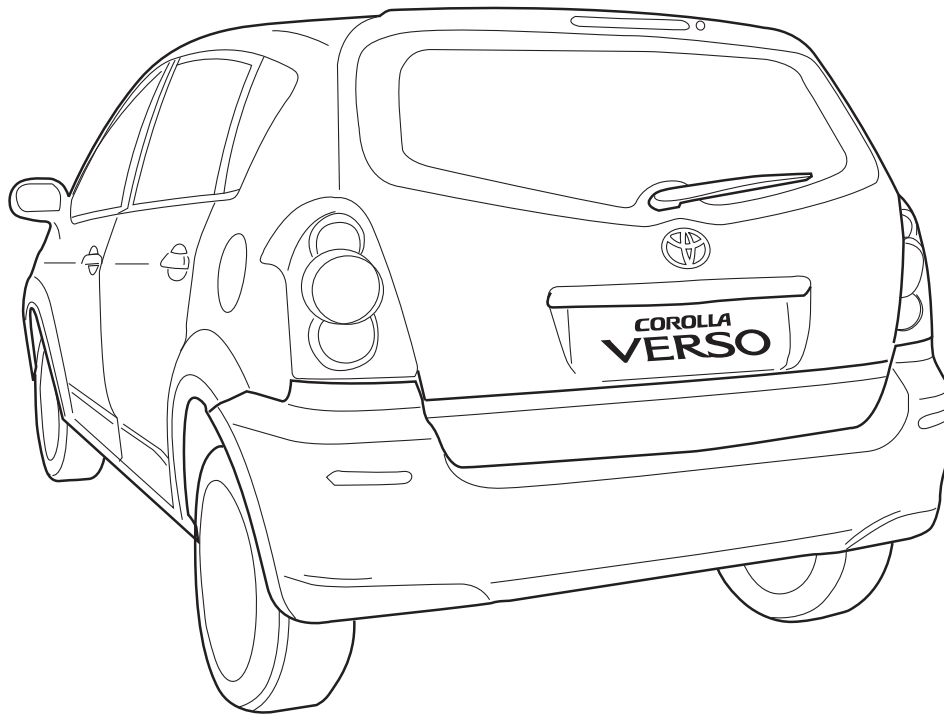

1

© 443770/27-08-2004/5

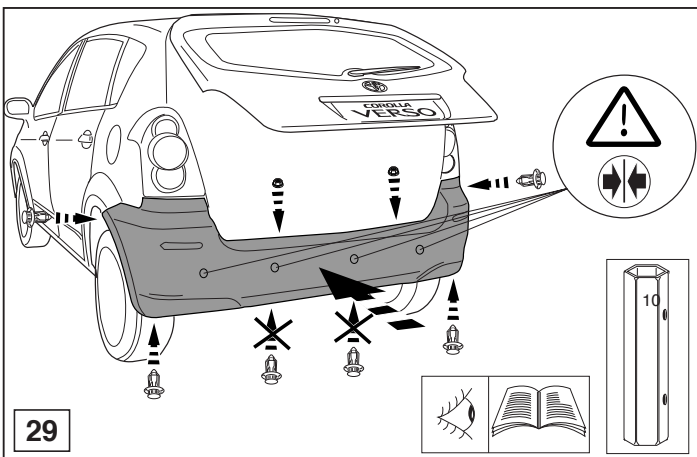

29

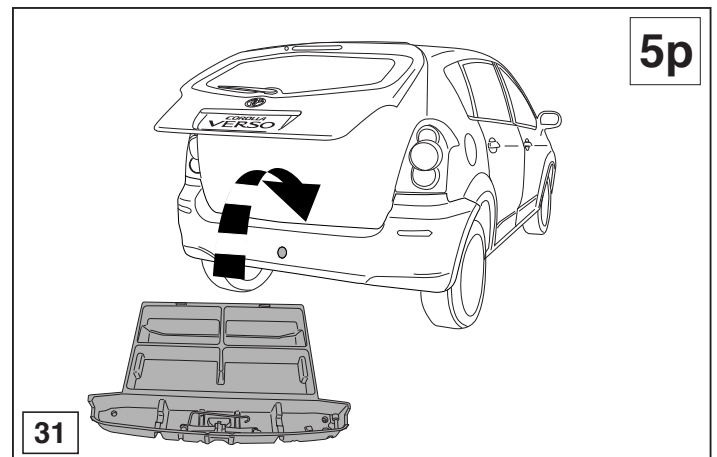

5p

31

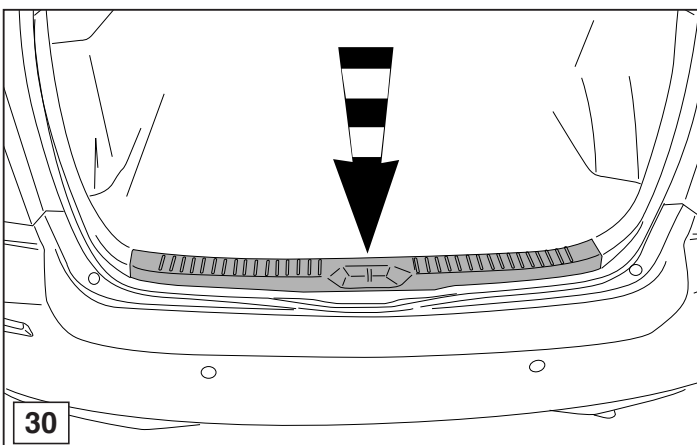

30

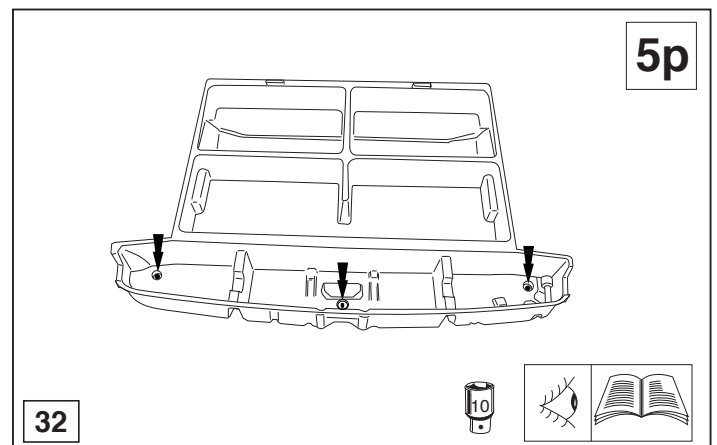

5p

32

© 443770/27-08-2004/14

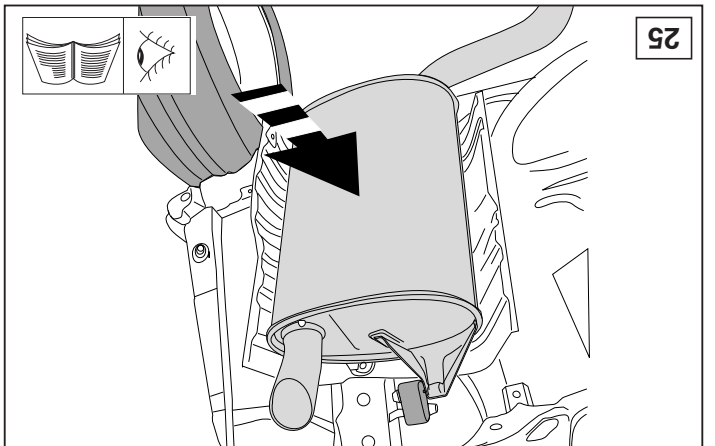
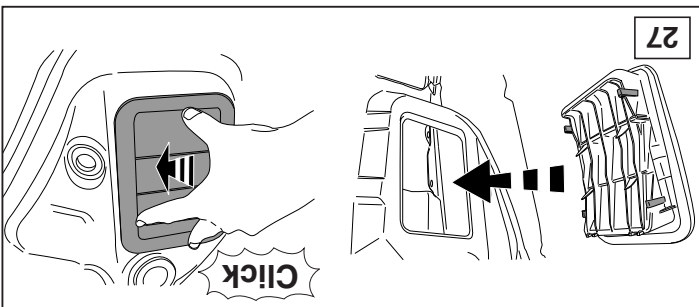
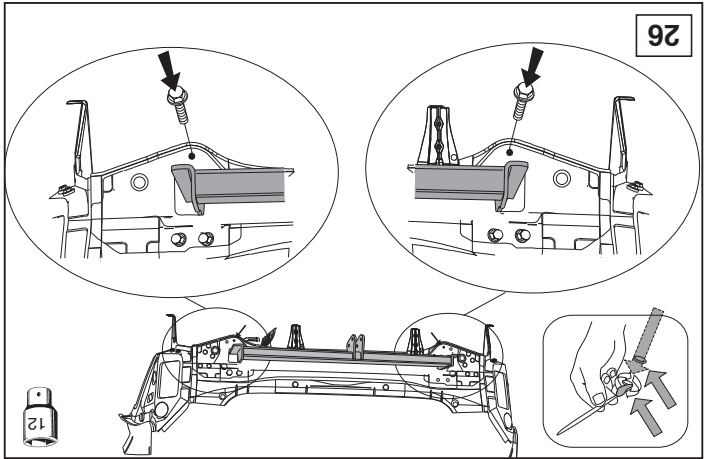
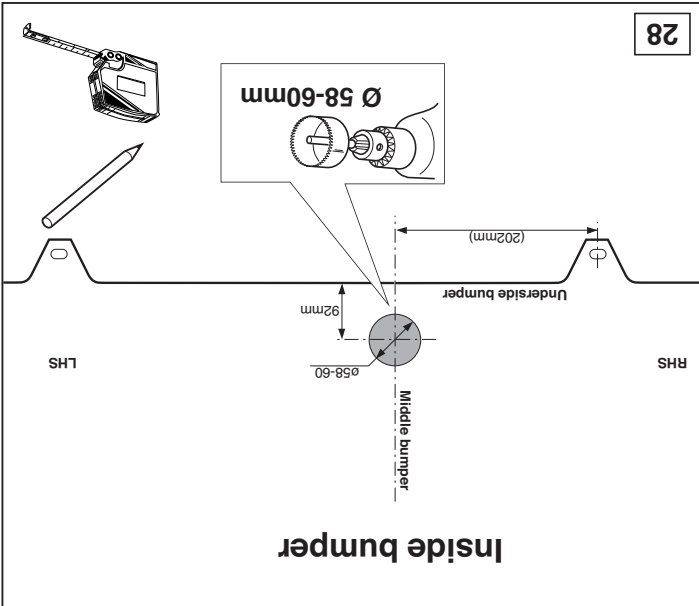
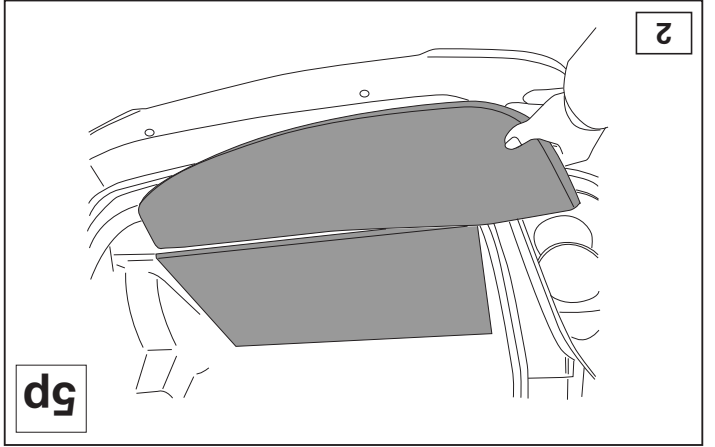
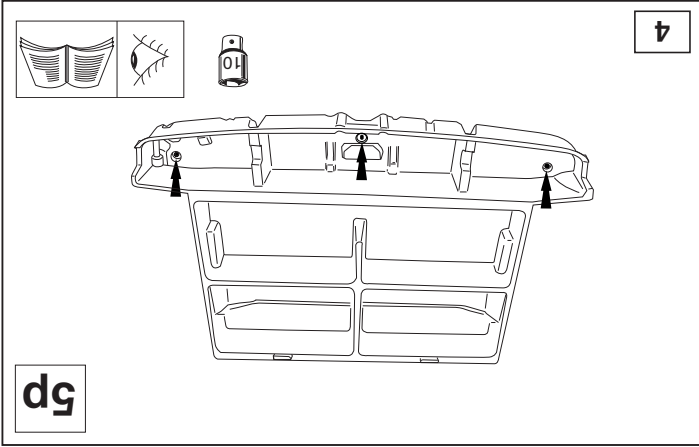
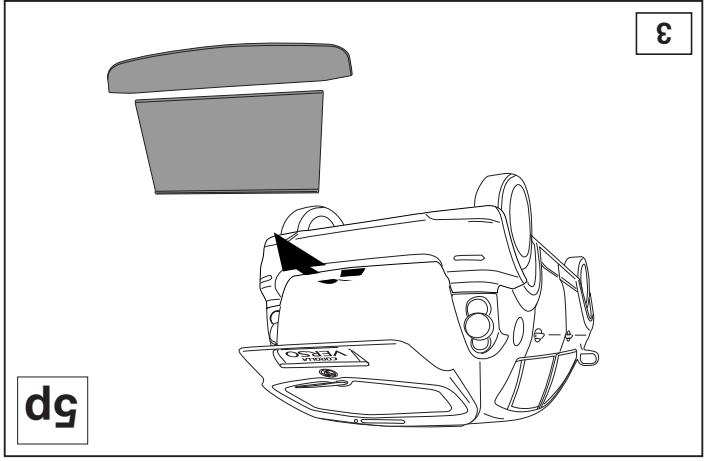
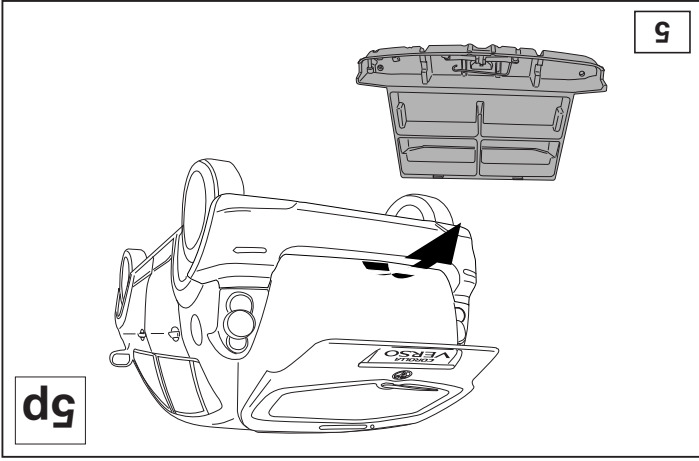

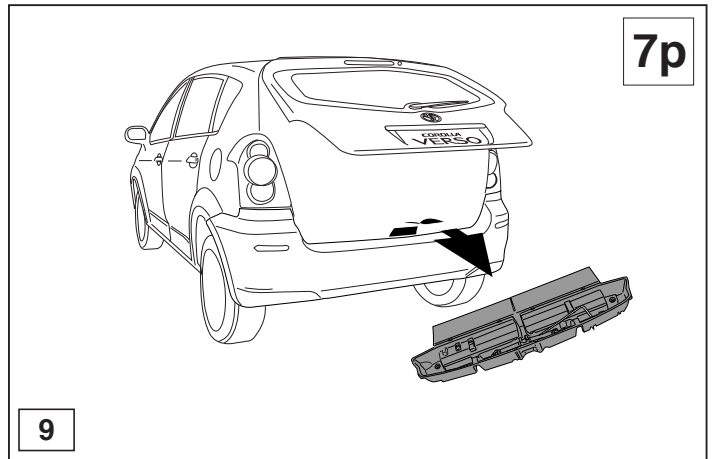
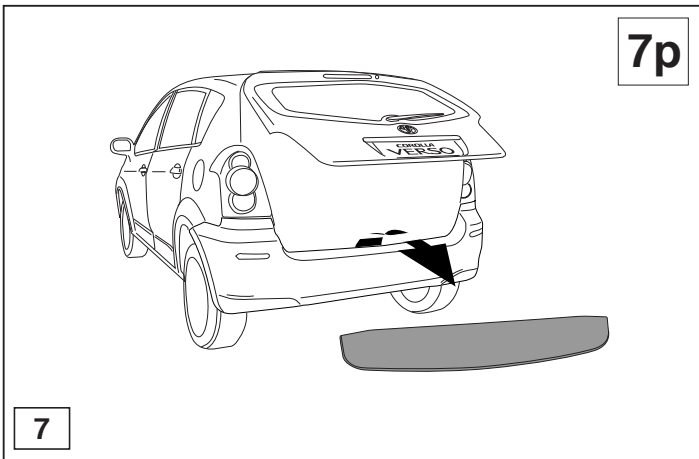
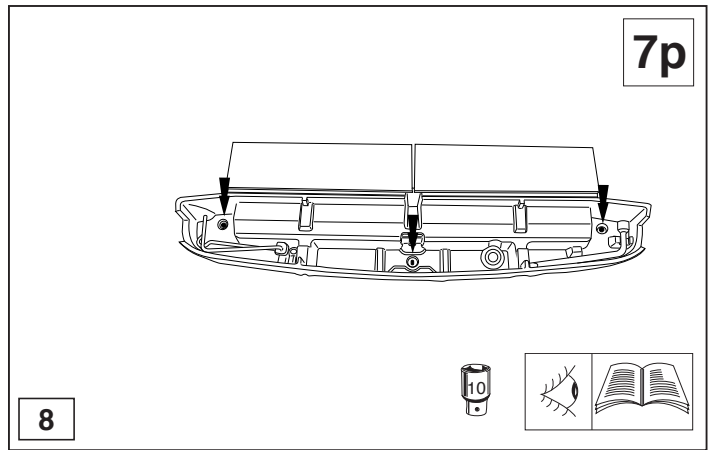
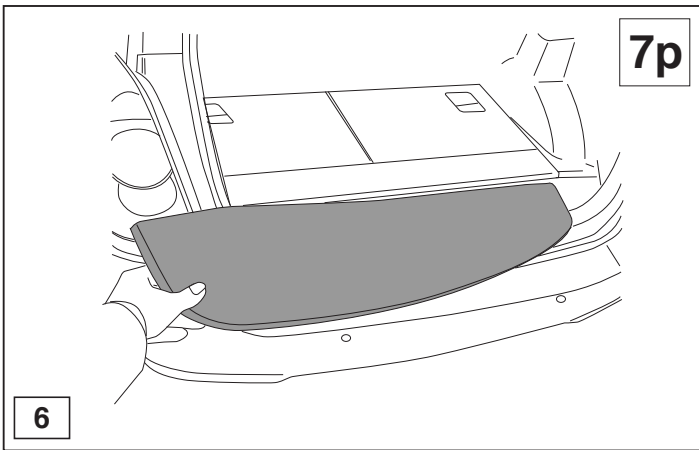

© 443770/27-08-2004/7

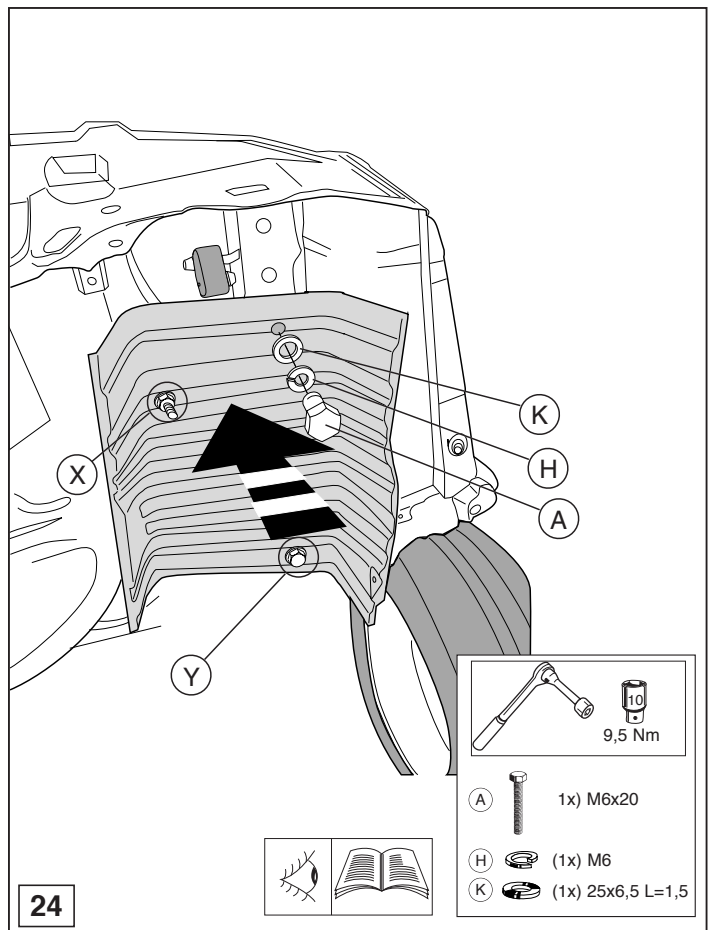
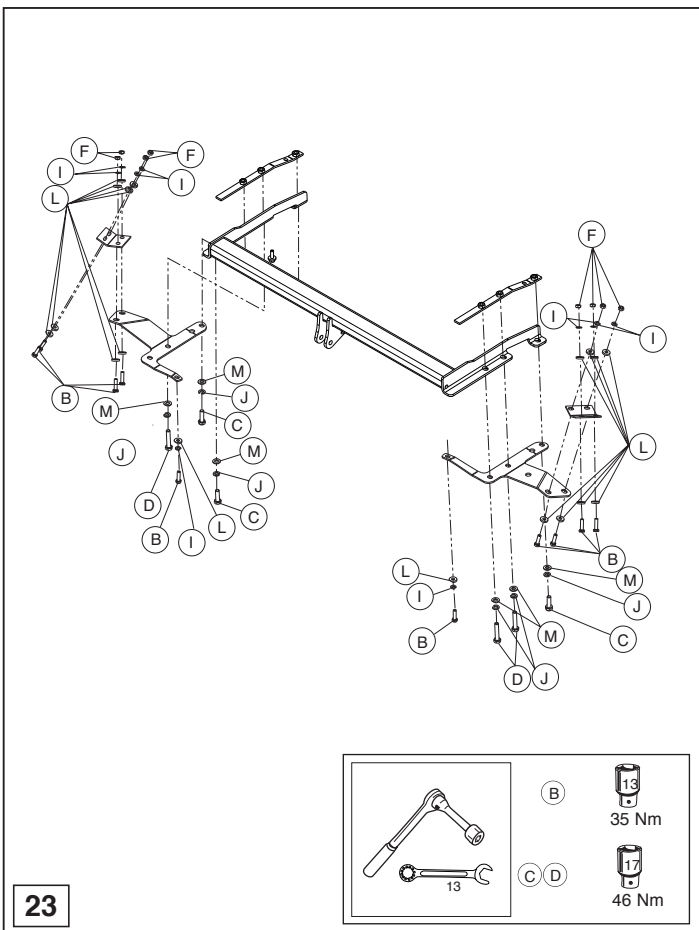

© 443770/27-08-2004/12



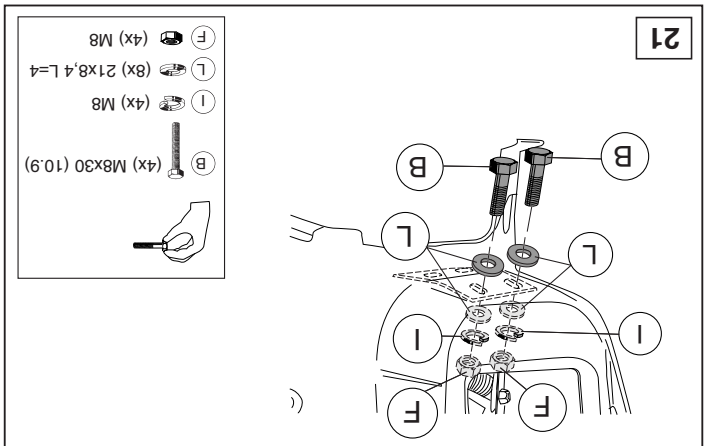
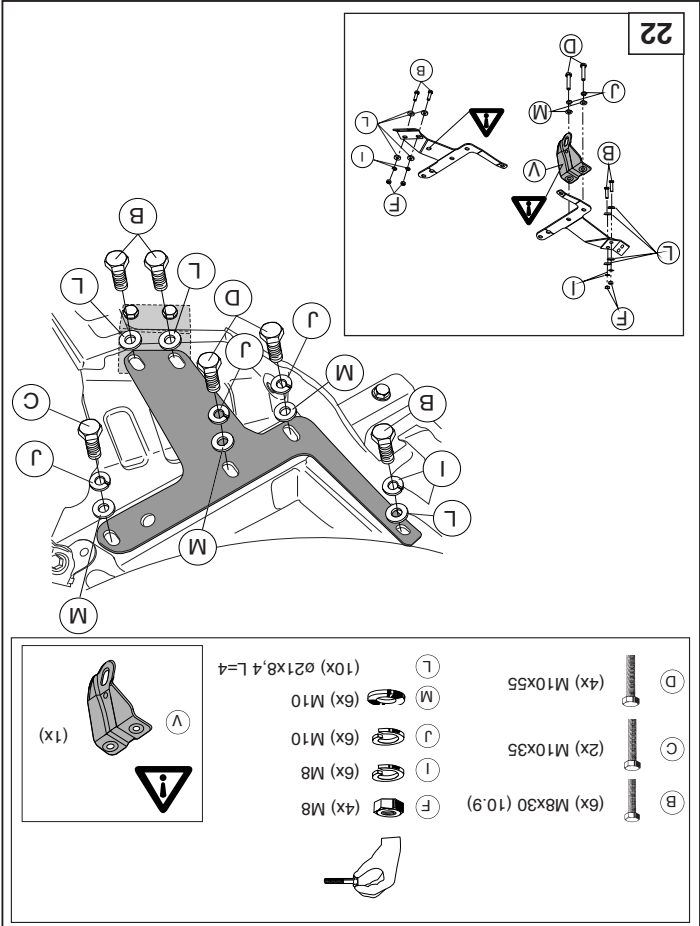
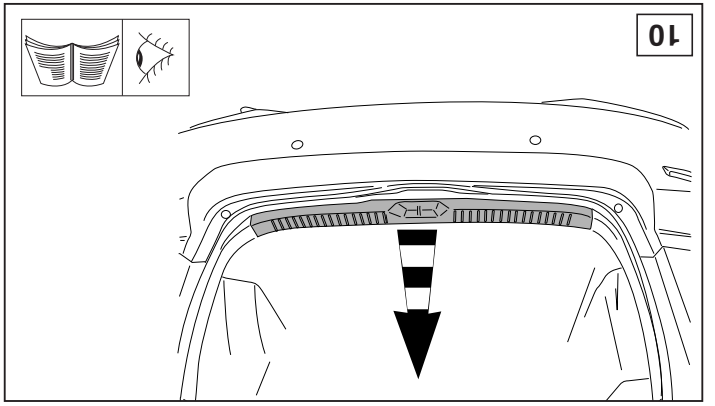
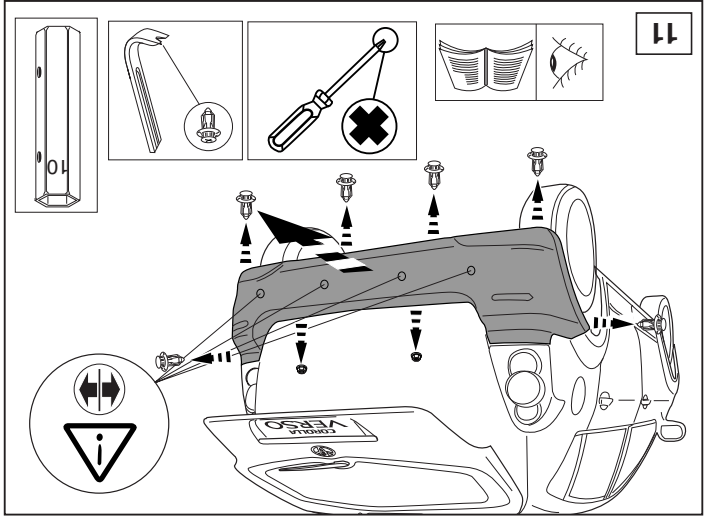
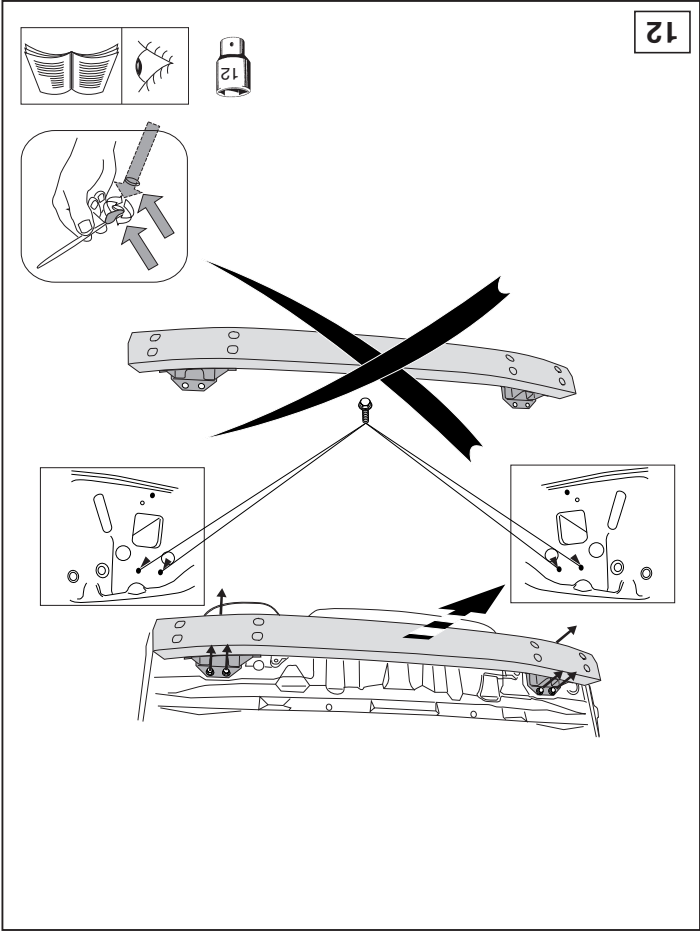

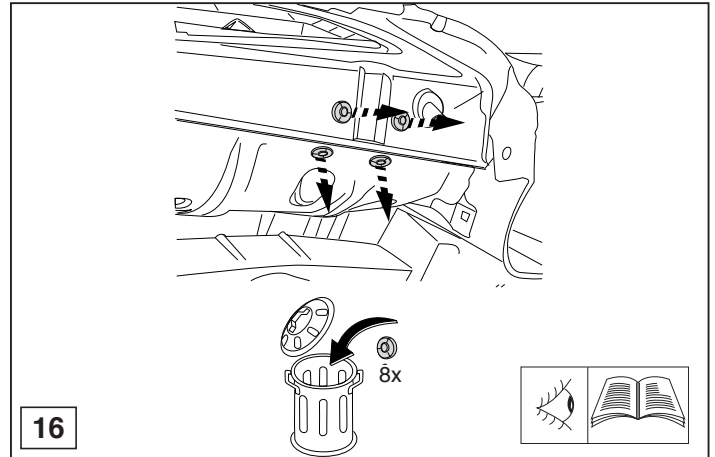
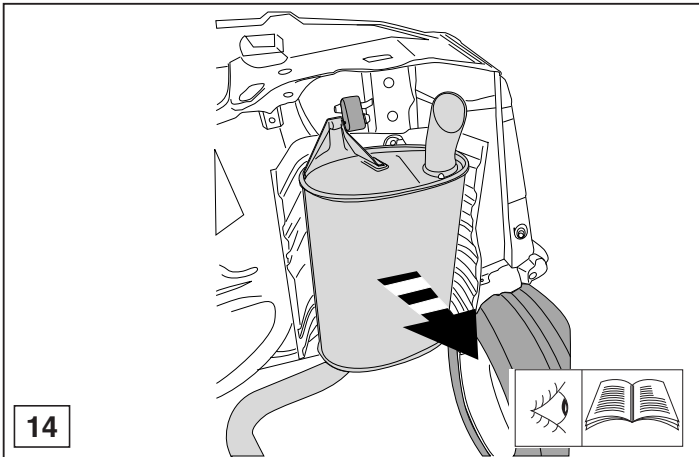
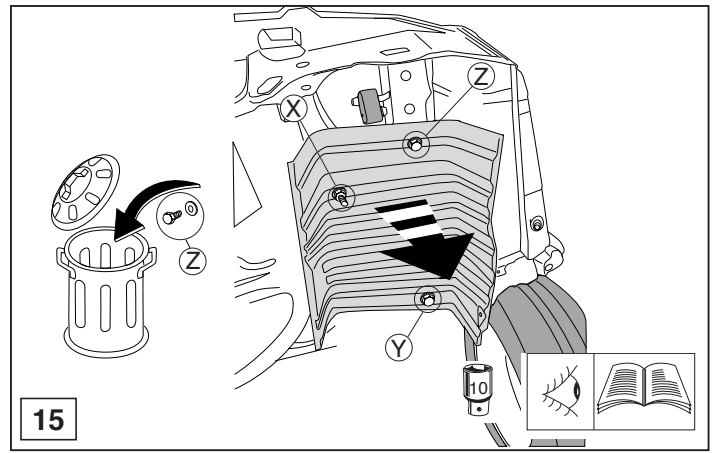
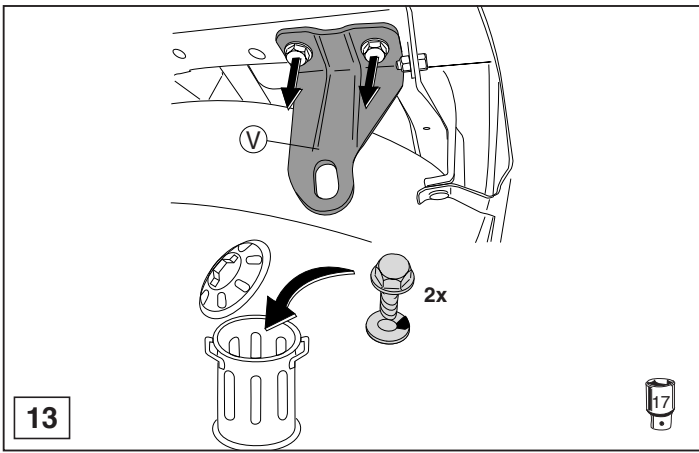

© 443770/27-08-2004/9

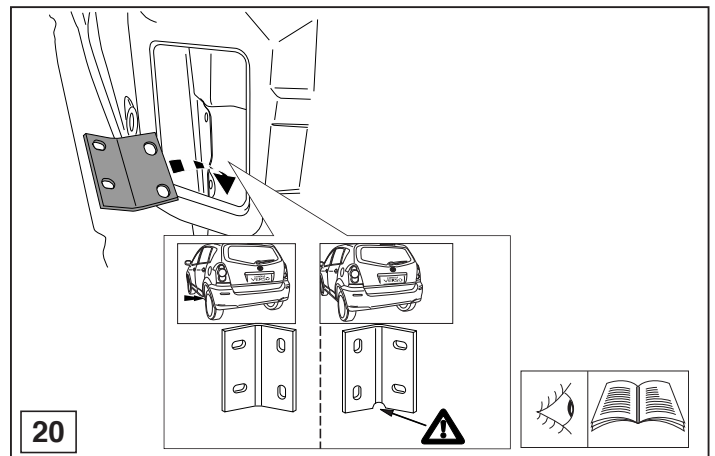
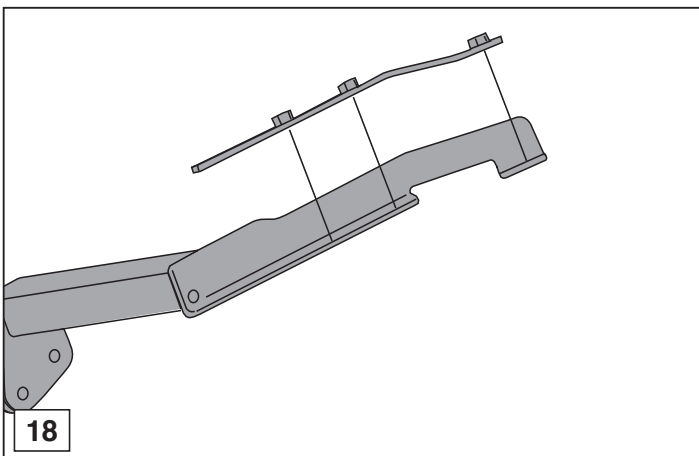
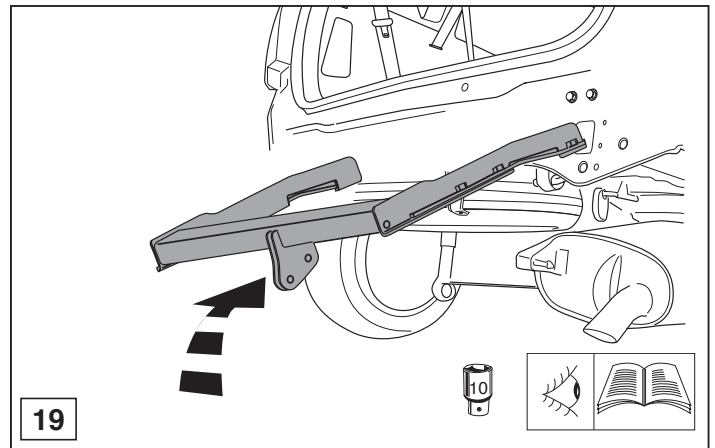
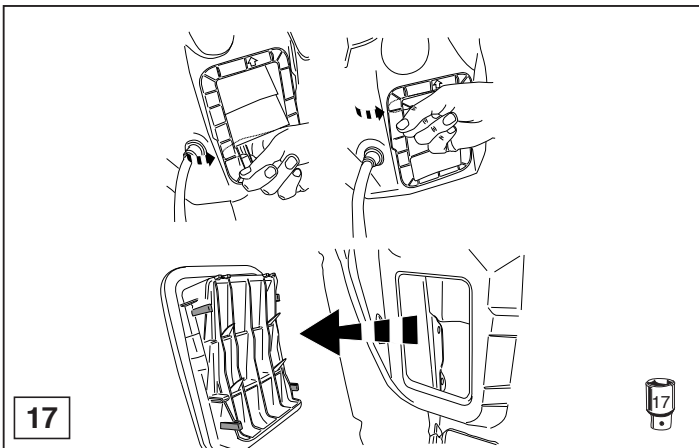

© 443770/27-08-2004/10