

Fitting instructions

Make: Hyundai

i20; 2008->

Type: 5082

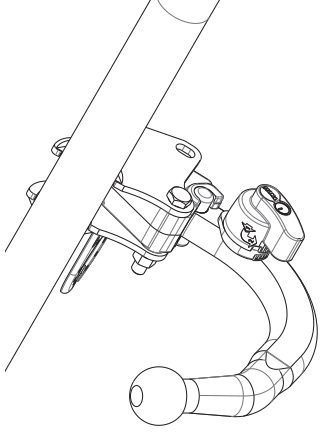

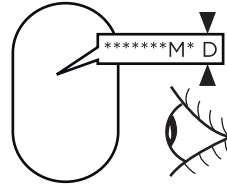

ser.nr:

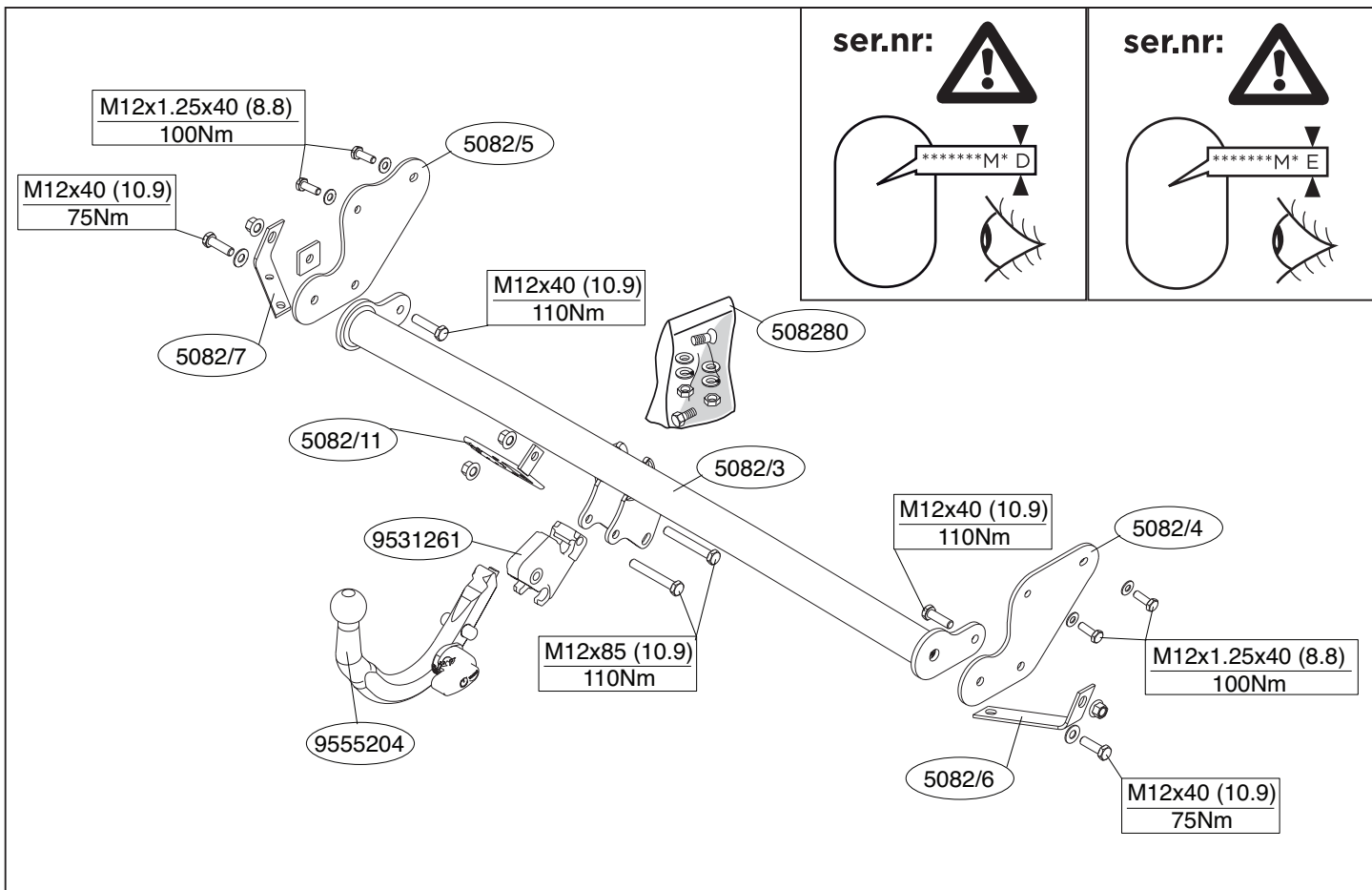
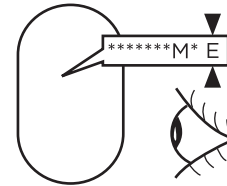

ser.nr:

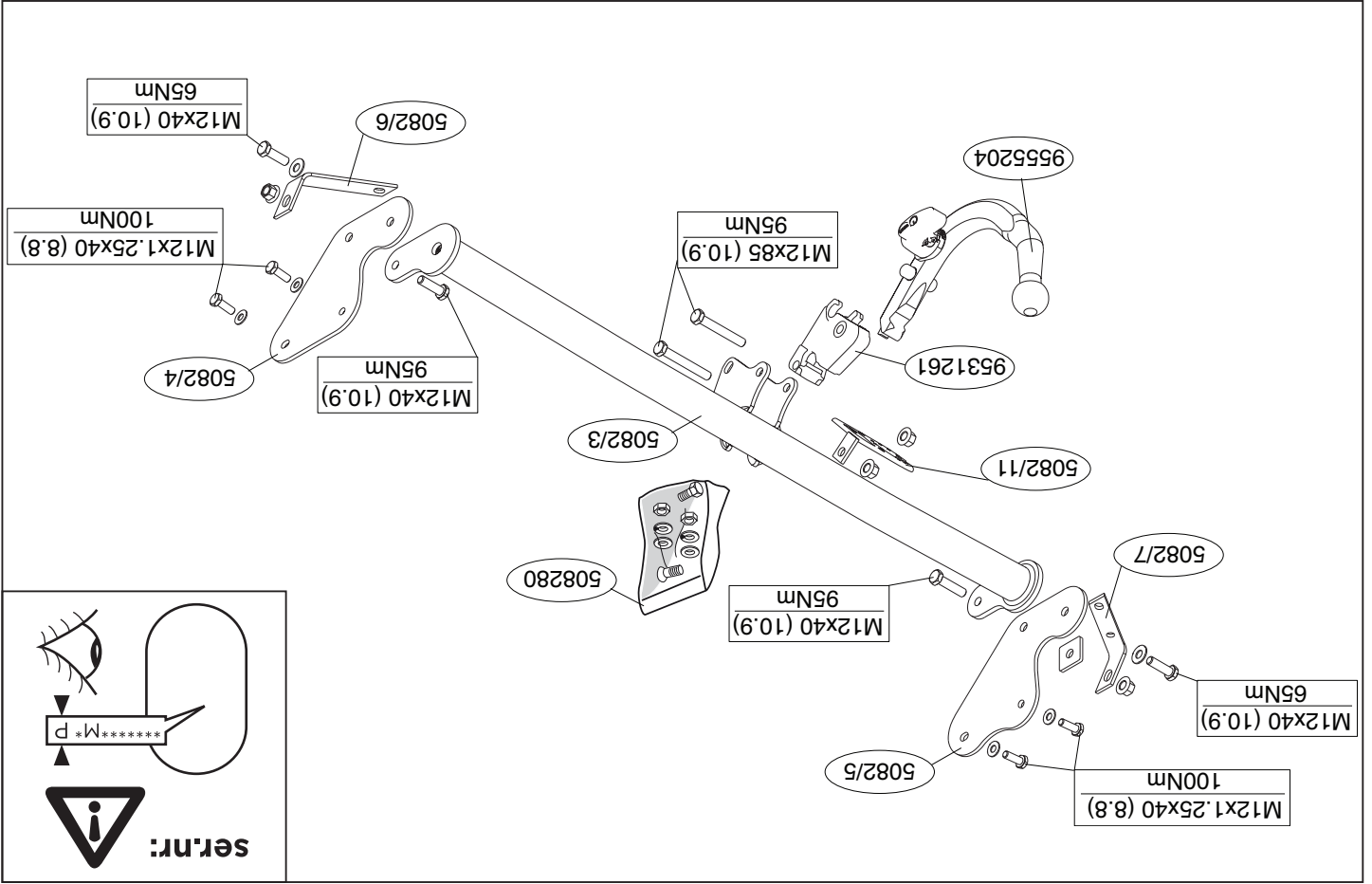

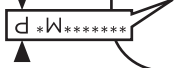

ser.nr:  



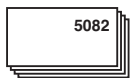
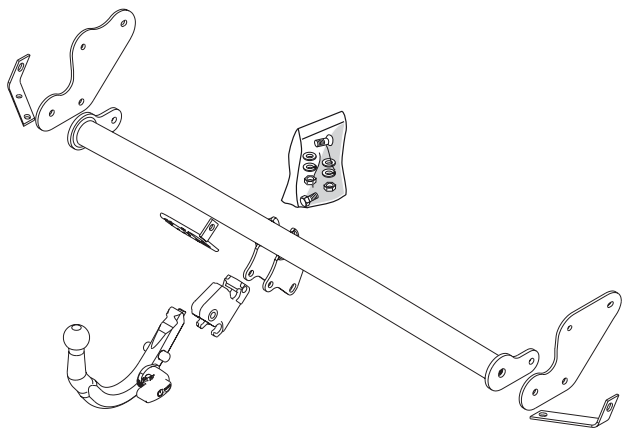
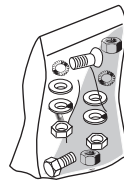
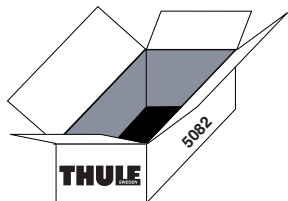

(2x) M12x85 (10.9)



(4x) M12



(4x) M12x50 (10.9)



(6x) M12



(4x) M12x1,25x40 (8.8)



(1x) 40x40x5

© 508270/03-04-2014/3

© 508270/03-04-2014/12

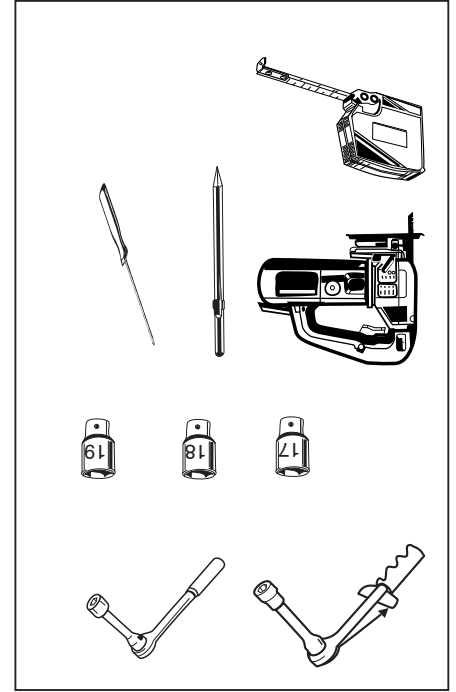
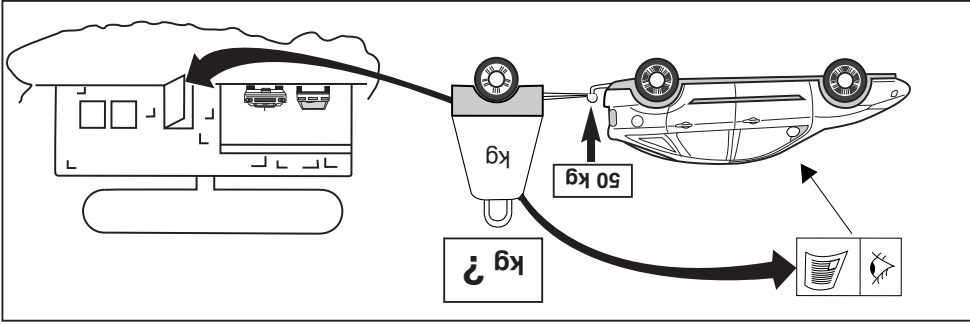
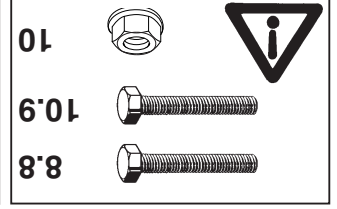
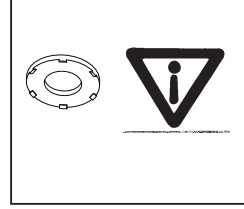
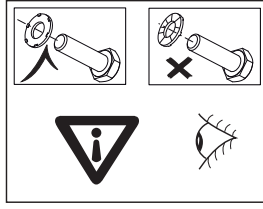
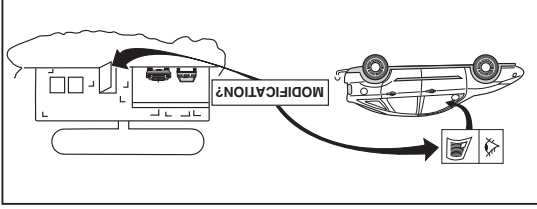

D-Value : 6,5 KN

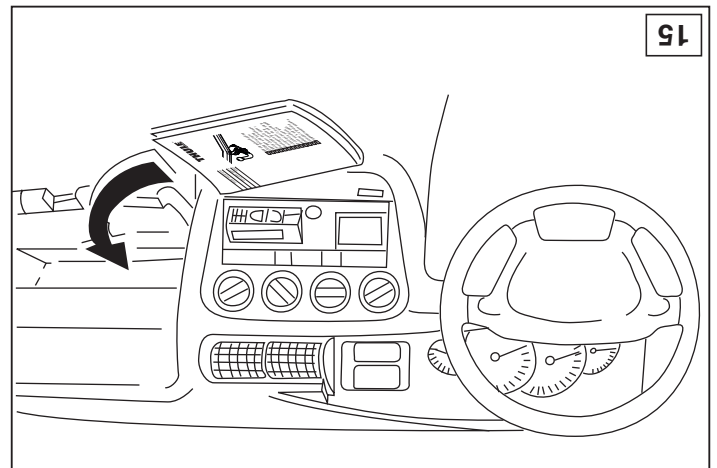
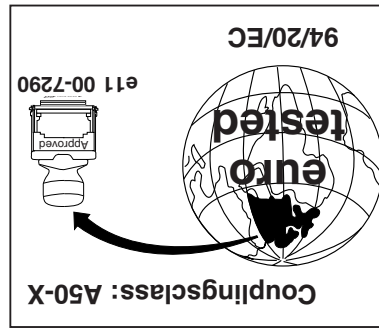

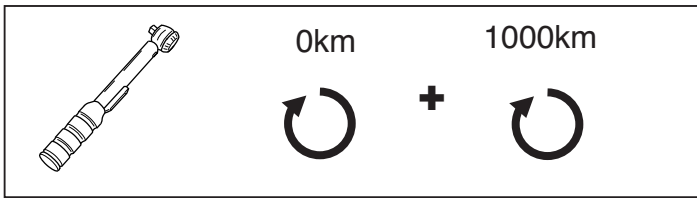

NOTE:

* Should this installation process entail the cutting of the bumper – conformation **MUST** be obtained by the installation engineer of the customer’s acceptance prior to completion. Thule Towing Systems do not accept responsibility for any matters arising as a result of this miscommunication.

All measurements are in mm!

HINWEISE:

* Die für das Fahrzeug zugelassene Anhängelast ist den Fahrzeug Unterlagen zu entnehmen. Bei Änderungen des Fahrzeuggewichtes muß die höchstzulässige Anhängelast gegebenenfalls aus dem D-Wert nachgerechnet werden.

Auskunft hierüber kann Ihr Fachhändler oder der TÜV geben.

* Elektrische Anlage gemäß StVZO anbringen.

© 508270/03-04-2014/5

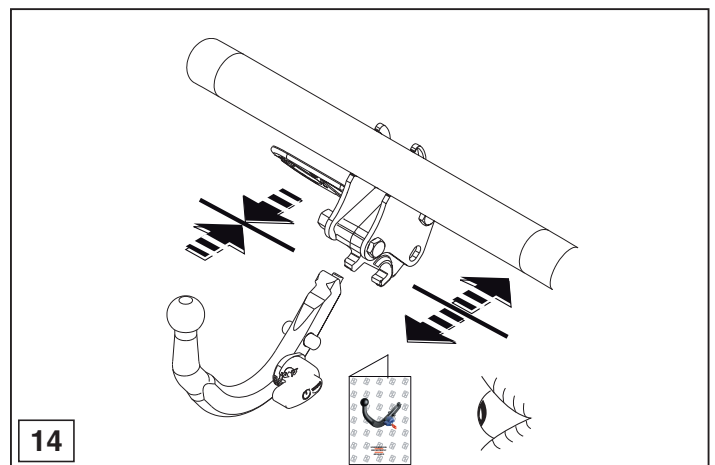
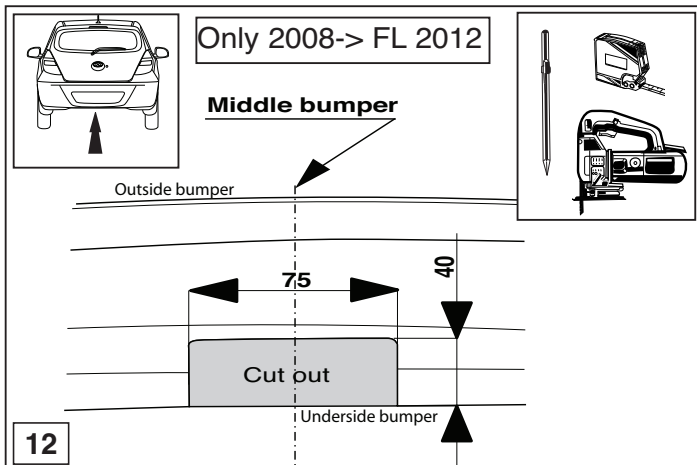
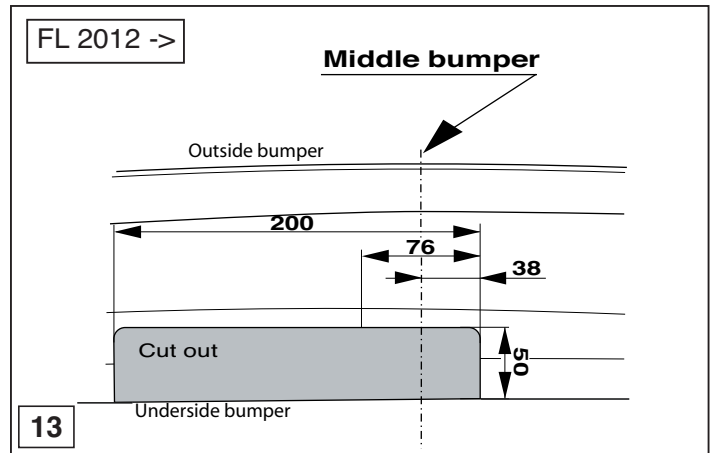
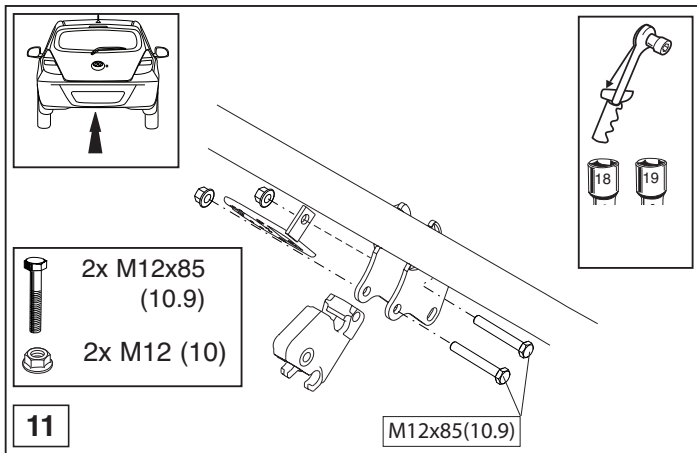

© 508270/03-04-2014/10

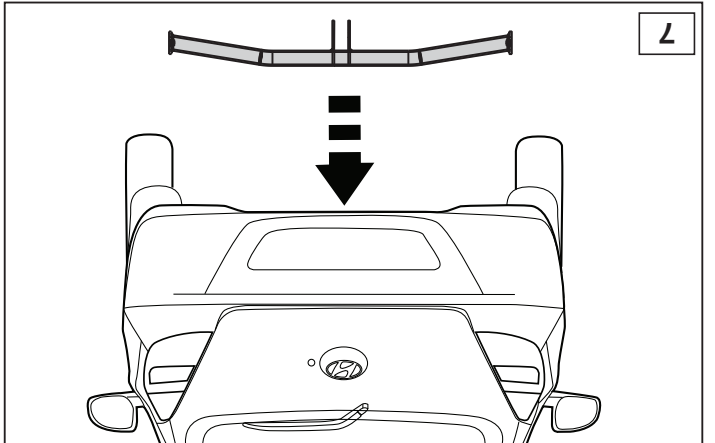
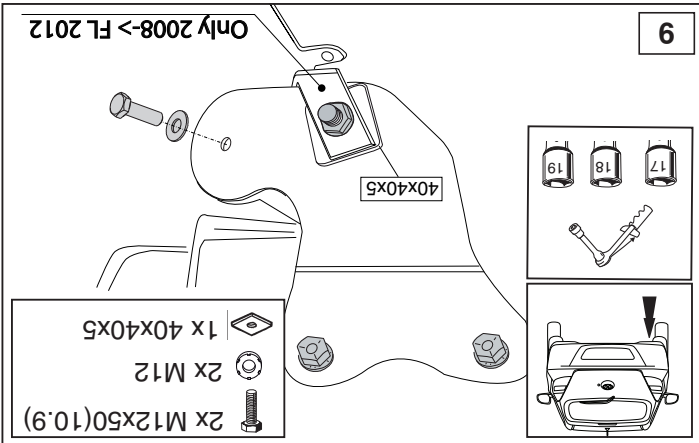
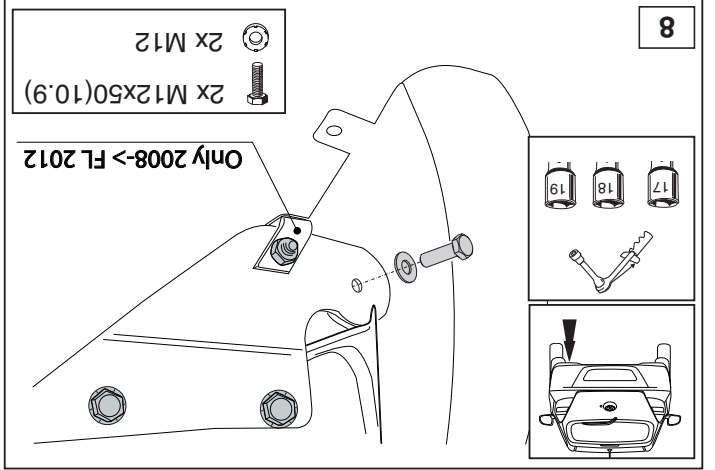
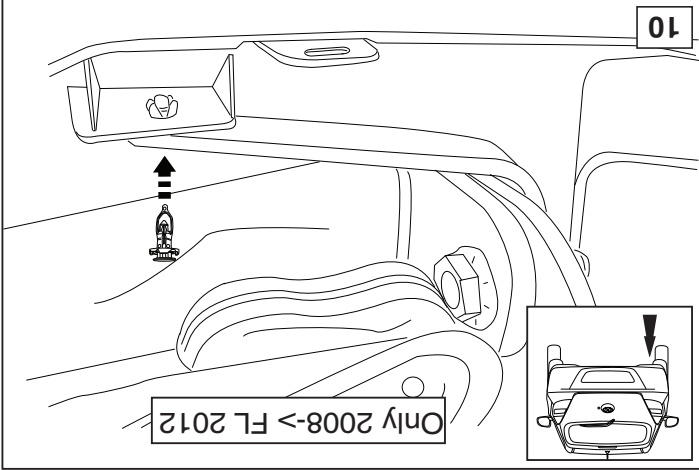
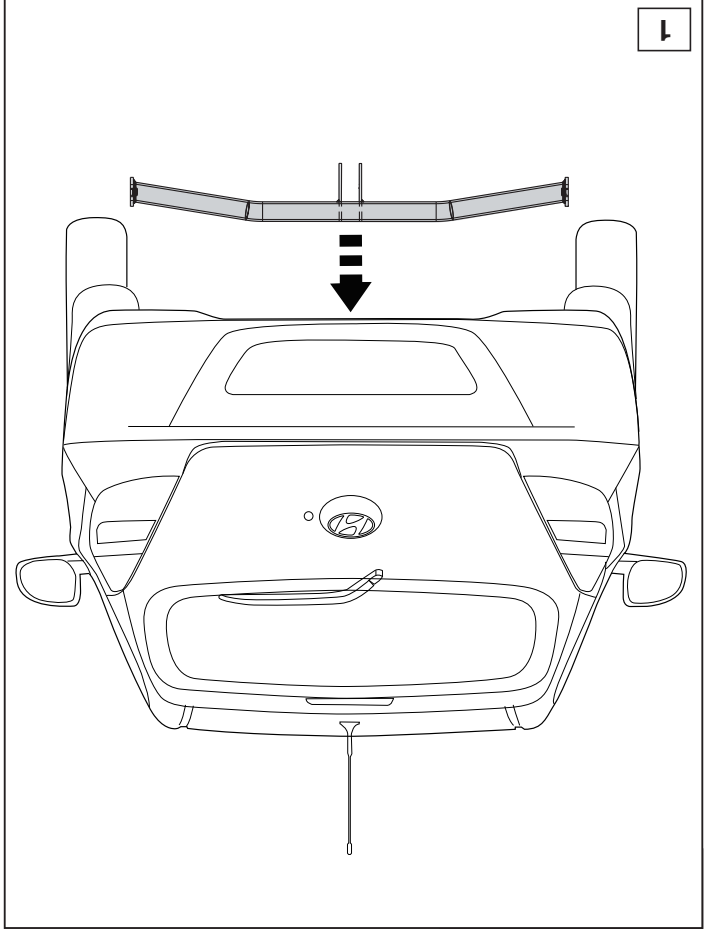
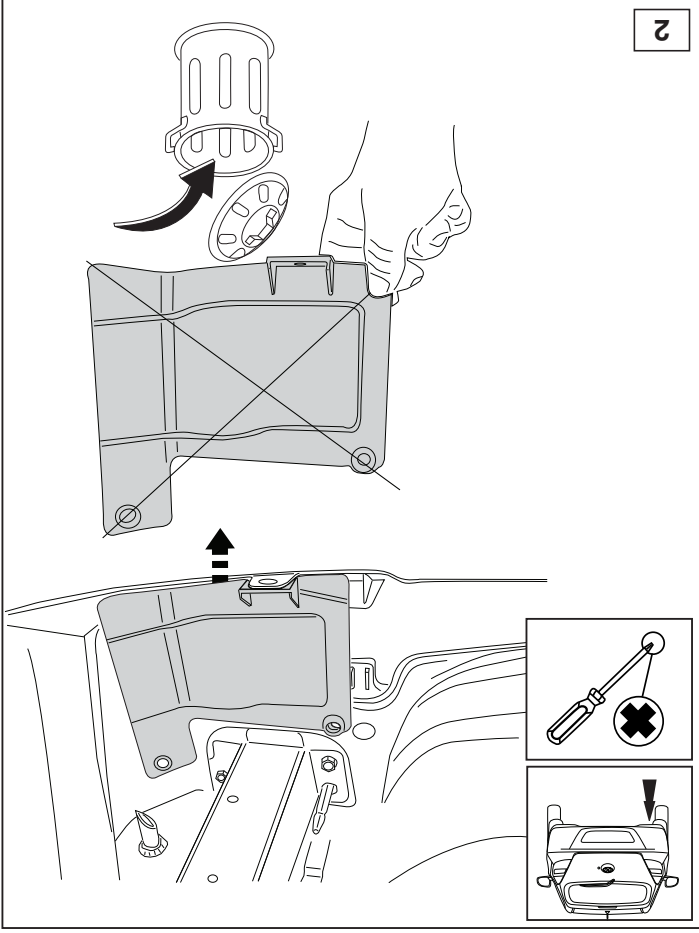

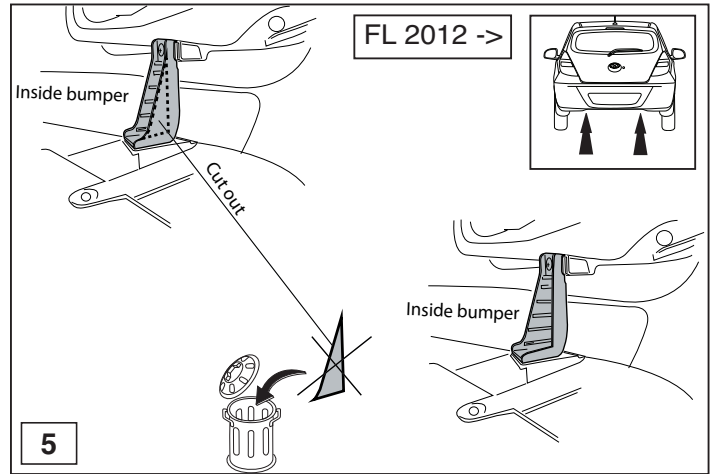
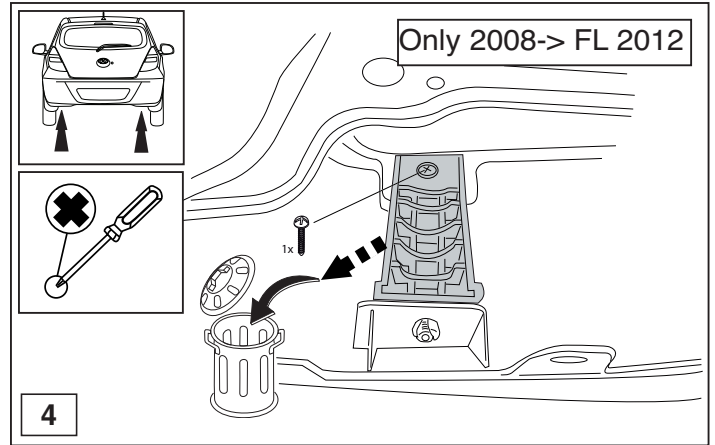
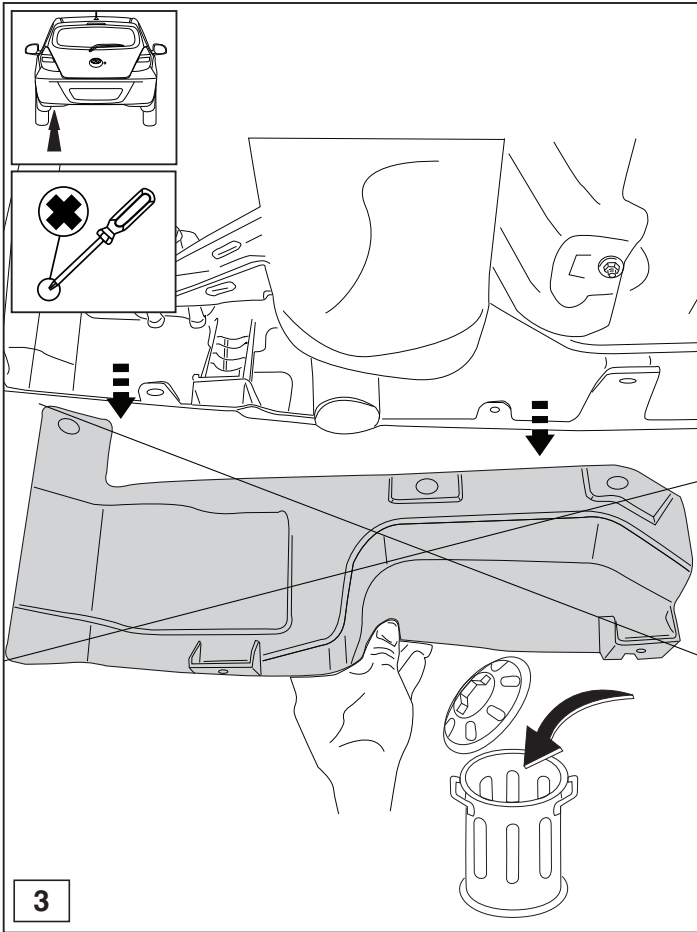

© 508270/03-04-2014/7

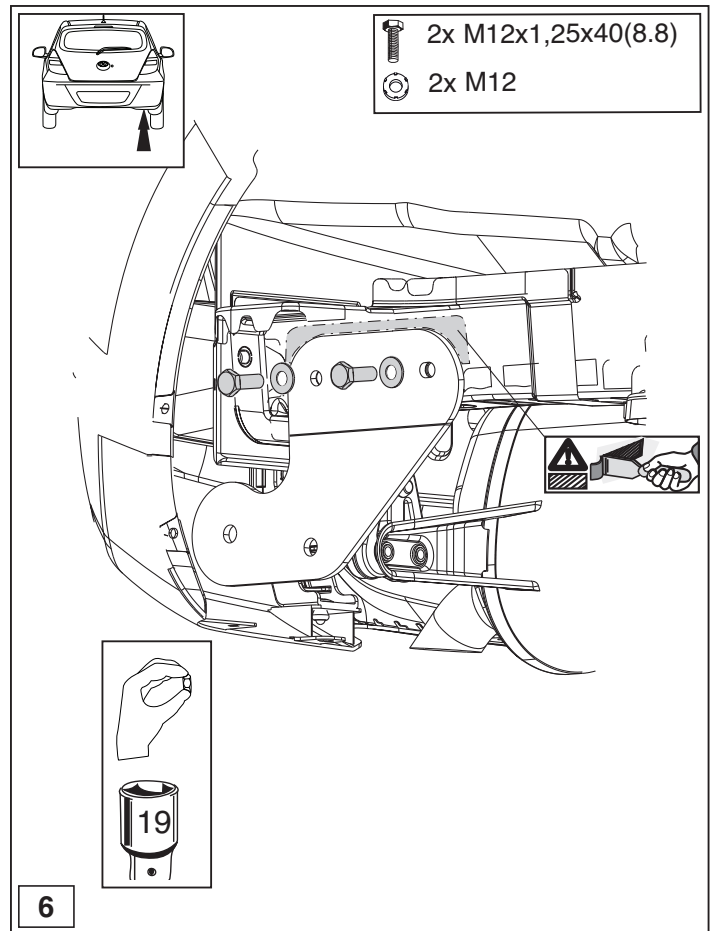
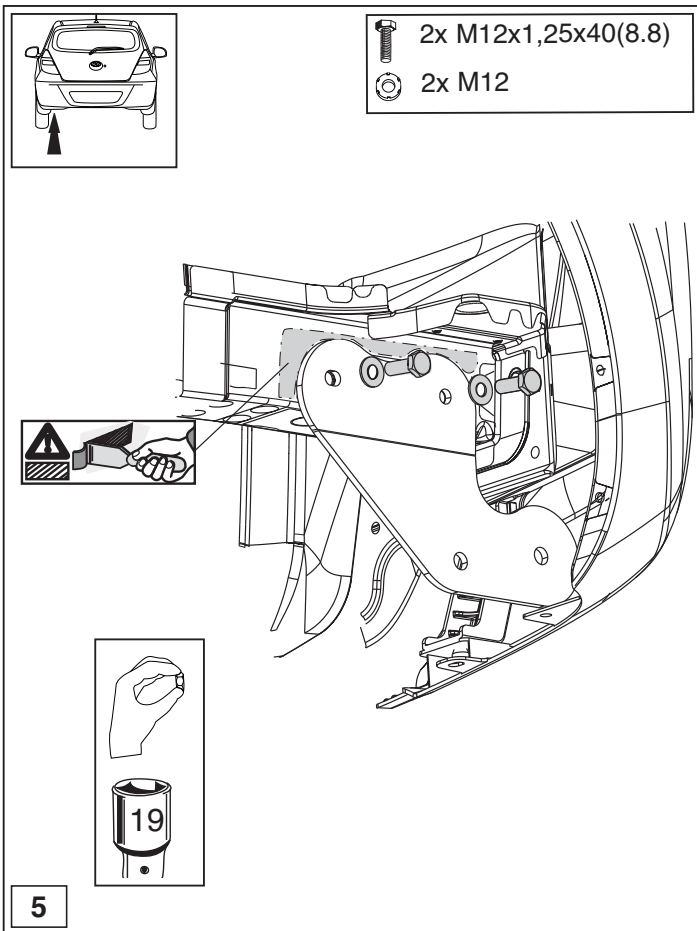

© 508270/03-04-2014/8